



sparco
Kids

BOOSTER CUSHION SK100IB

INSTRUCTION MANUAL

GB

ES

FR

DE

IT

PT

NL

Universal
Booster
Cushion
125-150cm



sparco
Kids

ECE R129/03

202405

DIRECTORY

| | |
|------------------------------|----|
| 1. Structure Name..... | 3 |
| 2. Installation..... | 4 |
| 3. Approval..... | 6 |
| 4. Installation..... | 7 |
| 5. Care And Maintenance..... | 9 |
| 6. Disposal..... | 9 |
| 7. Safety Notes..... | 10 |

STRUCTURE NAME

GB

ES

FR

DE

IT

PT

NL

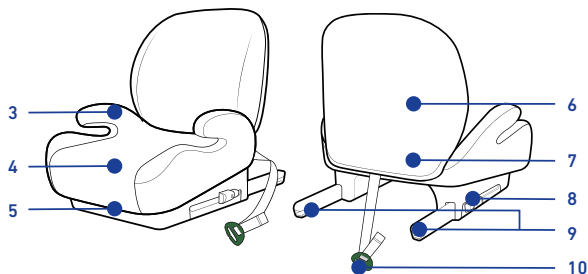

1. ISOFIX Insertion Aids (optional)
2. ISOFIX Fastening Points (vehicle)
3. Armrests
4. Seat Cover
5. Base
6. Waist Cushion (optional)
7. Release Buttons
8. ISOFIX Buttons
9. ISOFIX Locking Arms
10. Vehicle Belt Clip

INSTALLATION

1.ISOFIX

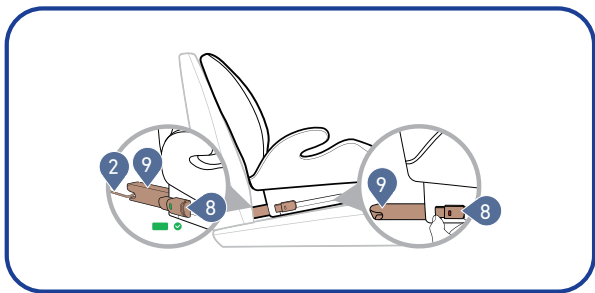
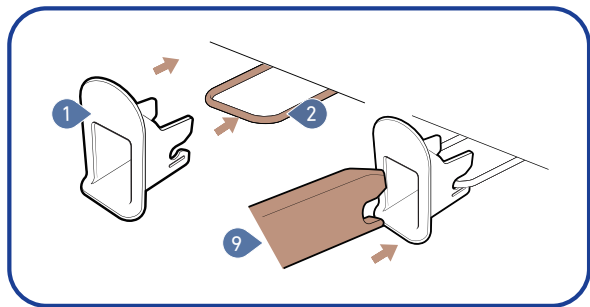

INSTALLATION

GB

ES

FR

DE

IT

PT

NL

2.USING

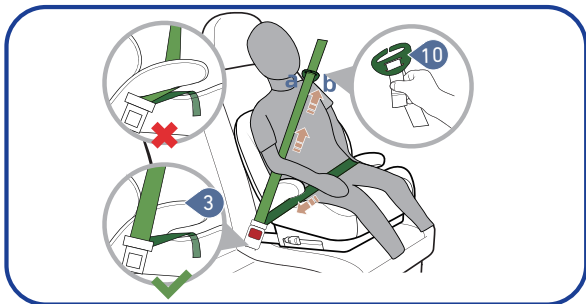

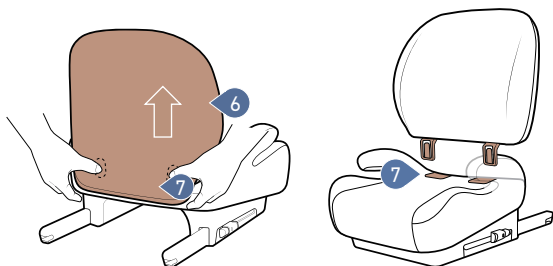

3.WAIST CUSHION



APPROVAL

These instructions use the following symbols:

| Symbol | Keyword | Explanation |
|--|-----------------|---------------------------------------|
|  | DANGER! | RISK of severe personal injury |
|  | WARNING! | RISK of minor personal injury |
|  | CAUTION! | RISK of material damage |
|  | TIP! | Useful notes |

The T005F PRO is exclusively intended to secure your child in your vehicle.

| Tested and approved according to ECE R129 | | |
|---|--------------------------|------------------------|
| Body size | Installation method | Installation direction |
| 125-150cm | Adult Safety-Belt+ISOFIX | Facing forwards |
| | Adult Safety-Belt | |

*ECE=European Standard for Child Safety Equipment

The child safety seat has been designed, tested and approved according to the requirements of the European Standard for Child Safety Equipment (ECE R129/03).

The seal of approval "E" (in a circle) and the approval number are located on the orange approval label (sticker on the child safety seat).

INSTALLATION

GB

ES

FR

DE

IT

PT

NL

1. ISOFIX

1.If your vehicle is not fitted with ISOFIX Insertion Aids (1) as stand- ard, clamp the two ISOFIX Insertion Aids (1), which are included in the scope of delivery of the seat , with the opening pointing upwards, to the two ISOFIX Fastening Points (2) of your vehicle.

TIP!The ISOFIX fastening points are located between the sur- face and the backrest of the vehicle seat.

2.Press the ISOFIX Buttons (8) to push out the two ISOFIX Locking Arms (9) from the seat base.

3.Push back the child safety seat until you hear a clicking sound then on both sides of the ISOFIX indicator turn into green safety color.

4.Move the child safety seat backwards to against the vehicle seat, to confirm the child safety seat is firmly against the vehicle seat.

TIP!Release button towards each other to loosen the ISOFIX fastening point on both sides. Move the ISOFIX locking arms back into the seat base, it can protect ISOFIX.

2. Using

ISOFIX+Adult safety-belt or Adult safety-belt only.

1.Place the universal booster cushion on the vehicle seat.

If you don't have ISOFIX,please ignore this Step.Install the univer- sal booster cushion with the adult safety-belt.

2.Let the child in the universal booster cushion. Pull out the belt from the belt ALR (Automatic Locking Retractor).

3.Guide the shoulder belt into the Vehicle Belt Clip (10) as shown,please guide the shoulder belt into it ,and adjust the length of the strap to make the shoulder belt slightly higher than the child's shoulder.When fasten the adult safety- belt, making sure the lap belt passes under both Armrests (3), while the shoulder belt is above the armrest.

INSTALLATION

TIP! Keep the shoulder belt at the position of belt guidance between the outside of the neck and shoulder (in the middle of point a and point b).

WARNING! The adult safety-belt must not be twisted or have their places changed over.

Pull the strap, adjust the height of the Vehicle Belt Clip (10) to adapt to children of different heights.

TIP! The importance of ensuring that any lap belt is worn low down, so that the pelvis is firmly engaged, shall be stressed.

Lock the tip of the buckle into the vehicle seat buckle with a clicking sound. Follow the direction of arrow to tighten belt, and put redundant belt into ALR. Shake the child safety seat to make sure it is securely attached.

TIP! The shoulder belt section must run diagonally backward. You can adjust the course of the belt with your vehicle's ALR on both sides.

3. Waist Cushion

1. Raise the Waist Cushion (6) at 90 degree angle. Insert the two plastic tongues of the Waist Cushion (6) to the connection holes of the base.

2. If you want to separate them, press the Release Buttons (7) by your finger.

Whether you remove the Waist Cushion (6) or not, using method is the same.

If you don't have Waist Cushion (6), please ignore it.

CARE AND MAINTENANCE

Universal booster cushion

Only use authentic T005F Pro seat covers. The seat cover is an integral part of the universal booster cushion and is key to ensure the trouble-free functionality of the system.

Replacement seat covers are available from your dealer.

The cover can be removed and washed with a mild detergent on a washing.

The plastic parts can be cleaned with soapy water. Do not use any caustic cleaning agents (such as solvents).

 **TIP!** Use seat cover R-elf to assemble cover more easily.

DISPOSAL

Please observe the waste disposal regulations in your country.

| | |
|-----------------------|--|
| Disposal of packaging | Container for cardboard boxes |
| Seat cover | Residual waste, waste incineration |
| Plastic parts | To be placed in the corresponding container according to labelling |
| Metal parts | Container for metals |

GB

ES

FR

DE

IT

PT

NL

SAFETY NOTES

NOTICE

Notice Regarding Universal booster cushion category Enhanced Child Restraint Systems.

This is a Universal booster cushion Enhanced Child Restraint System. It is approved according to UN Regulation No.129, for use in i-Size compatible and universal vehicle seating positions as indicated by vehicle manufacturers in the vehicle user's manual.

If in doubt, consult the Enhanced Child Restraint System manufacturer or the retailer.

SAFETY NOTES

DANGER! ⚠

Please carefully read and make sure you understand all instructions in this manual and in the vehicle handbook relate to child safety seats. Install and use the child safety seat as described in the instruction manual. Failure to do this could result in serious injury even death of your child. Keep the instructions together with the ECRS for future reference.

Make sure any straps holding the ECRS to the vehicle should be tight. Any straps restraining the child should be adjusted to the child's body. Make sure straps should not be twisted.

Make sure the lap vehicle seat belt must be worn in such a way as to properly secure the pelvis of the child.

Make sure the ECRS is changed when it has been subject to violent stresses in an accident.

Make sure the rigid items and plastic parts of a ECRS shall be so located and installed that they are not liable, during everyday use of the vehicle, to become trapped by a movable seat or in a door of the vehicle.

DO NOT make any alteration or additions to the ECRS without the approval of the Type Approval Authority, or a danger occurs if not following closely the installation instructions provided by the child restraint manufacturer.

HOT! The child seat should be kept away from sunlight if the seat is not provided with a textile cover, otherwise it may be too hot for the child's skin.

DO NOT leave your child unattended in this restraint even for a short time.

Make sure any luggage or other objects liable to cause injuries in the event of a collision shall be properly secured.

A) DO NOT use the ECRS without the cover.

B) DO NOT replace seat cover with any other than the one recommended by the manufacturer, because the cover constitutes an integral part of the restraint performance.

GB

ES

FR

DE

IT

PT

NL



Produced under Sparco's license by:
CARPA DESIGN EUROPE, S.L.
C/ Duque de Calabria, 4 bd, 46005 Valencia SPAIN
tel: +34 963 125 049, info@carpa-europe.com
www.carpa-europe.com

MANUALE
INSTRUCTION



CARTA
PAPER

Raccolta differenziata. Verifica le disposizioni locali.
Separate collection. Verify the local arrangements.